

Corner Beads: CB2

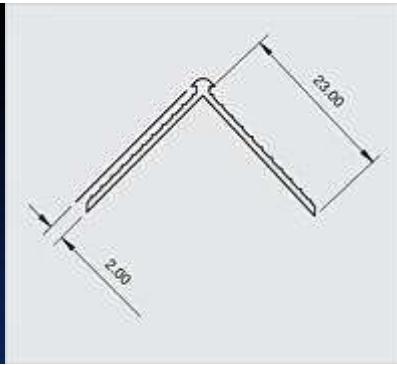

Locally manufactured from recycled plastic, Renderplas 2mm PVCu corner beads / angle beads are designed for function and speed on external and internal rendering and plastering applications. This lightweight profile is suitable on external wall insulation with a thin application of acrylic render, on plasterboard with skim plaster or for drylining / drywall systems

Performance: design data

Affiliations	Federation of Plasterers and Drywall Contractors	Fire	Class 1Y. Combustible within fire source, self extinguishing upon removal of flame, will not contribute to the combustion of the system
Applications	External wall insulation; internally in high moisture areas like kitchens, bathrooms and pool enclosures and any plasterboard drylining / drywall systems to form straight edges and to prevent cracking at external corners	Health and Safety	PVCu beads are safe to handle removing the dangers of cut metal; suitable for prisons and schools
Chemical	Zero chemical reaction with water, sand and cement, acrylic render, water based paint; avoid organic solvents, chlorate bleach, strong acids and alkalis	Heat	Ideal for all habitable conditions
Durability	Impact resistant; dissipates shock waves; outlasts metal; cleaned or painted in same way as plaster or render	Guarantees	Fit for purpose for at least 25 years
Economics	PVCu beads are faster to cut and fix than steel and are guaranteed not to stain or corrode in damp situations. They reduce casual damage on site and impact damage when fitted	Mechanics	-
Environment	Locally manufactured; high recycled content; fully recyclable; low Ecopoint score of 0.004/kg delivered	Pollution	Ecologically benign; non-hazardous in water; non-hazardous if ingested; does not release substances into the atmosphere
		Strength	PVCu beads offer superior resilience to impact
		Weather	Not affected by weather and should be specified in all regions of high moisture or high salt

Specification: standard data

Type	CB2	Weight (kg/100m)	5.4
Authority	BBA certified; manufactured to ISO 9001:2000; complies with BS EN 13914-1&2:2005; fire tested to BS 476; complies with REACH	Stock Colours	White
Brand Names	Renderplas	Length	2.5m
Description	2mm PVCu Corner Beads (Angle Beads)	Packaging	25 lengths in fibreboard tubes; 50 lengths in triwall boxes
Composition	Exterior grade impact resistant UV stable unplasticised PVCu	Format	Cut lengths
Dimensions (mm)	3.3mm arris and 23mm wings	Price (£/100m)	
Depth (mm)	2-3mm plaster or render	Recycled Content %	100.0%
		Light	UV stable; any discoloration is uniform over a single facade and within industry standards

Site works

Installation	Standard industry practice and tools can be used. Cut to length with tin snips or fine tooth saw. Non-corrosive mechanical fixings should be used	Storage	Store vertically out of direct sunlight or extreme temperatures. Can be stored flat if supported along entire length
		Supply	Ex-stock next day delivery to site through extensive supply chain or direct from www.renderplas.co.uk